

SOLUTIONS FOR TELEVISION PRODUCTION & VIDEO STREAMING



**3D STORM**

2013 PRODUCTS CATALOG



## Table of Contents

- LIVEXPERT TOOLS BY 3D STORM .....page 3
- TRICASTER .....page 7
- TRICASTER 410.....page 8
- TRICASTER 460 .....page 12
- TRICASTER 860 .....page 16
- TRICASTER 8000..... page 20
- CONTROL SURFACES..... page 24
- SOFTWARE ..... page 26
- 3PLAY ..... page 29
- 3PLAY 4800..... page 30
- 3PLAY 425 ..... page 34
- SYSTEMS COMPARATIVE TABLES... page 38
- VIRTUAL SETS TEMPLATES..... page 40
- 3D STORM SERVICES..... page 42

# LiveXpert™ Tools by 3D Storm

**LiveXpert Tools** is the new line of products for live production and Sport live production distributed by 3D Storm.

**LiveXpert Tools** give producers the ability to produce more content without compromising on budget and quality, and offer all the keys to see the big picture, take on more ambitious projects and make the difference.

**LiveXpert Tools** can be either used as plug-ins, as remote applications, or as independent products, giving TriCaster operators the freedom to focus on the production operations.

Enrich sports live productions with **LiveCG™ Football**, an exclusive tool dedicated to Football scoring, statistics and graphics management.

Give the audience all the information they need to live their dream. Enhance sponsors and advertisers visibility. Create a complete library of information to keep sports fans engaged and speed up production time for recurring games.

With **LiveMixer™**, don't leave the sound out of your live production, control the audio mixer of TriCaster remotely and instantly, with industry standard audio consoles such as the very affordable Behringer BCF 2000 or the sophisticated Yamaha 01v96i.

**LiveXpert Tools** enhance live production workflow, speed up production time, reduce costs, increase revenues opportunities and widen the audience with instant high quality media content to enjoy a full live experience.



LiveCG Football



LiveMixer





# LiveCG Football™

## Graphics Management for Sport Live Production – Football Edition

**LiveCG Football™** is a professional graphics management application for NewTek TriCaster™\*. It provides complete management of football live productions: scoring, timing, statistics, database (players names, referees, teams, leagues, countries...). **LiveCG Football** runs from a remote computer connected to the network input of a TriCaster.

The graphics, generated with **LiveCG Football** among the database of templates available within the application, or created with own custom branded details, give producers the ability to use high quality graphics for scores and statistics display, and also insert advertising and promotion visuals. With **LiveCG Football**, sports producers can enhance the viewers experience while increasing their revenue.

*\*Works through iVGA with up-to-date TriCaster systems.*



**More information**



# LiveMixer™

## Remote Audio Mixer Control for TriCaster

Control the audio of your TriCaster from an external console quickly and professionally.

**LiveMixer™** is a versatile application that provides a complete remote control over the audio mixer of all TriCaster HD professional line.

Associated to a physical audio control panel LiveMixer can be used as an add-On for TriCaster or it can be installed on an external computer connected with TriCaster through the local network.

**LiveMixer™** offers an efficient remote control of the TriCaster audio mixer from a physical console or a computer. With a dedicated sound operator using LiveMixer, the TriCaster operator can focus on the live production. LiveMixer is easy to install and easy to use, it comes with factory presets and can be customized to suit your needs. LiveMixer supports the very affordable Berhinger BCF2000 and the professional Yamaha 01V96i audio consoles.

*Compatible with TriCaster HD models.*

*For best performance make sure your TriCaster system is updated with the latest available software.*



**More information**





# TriCaster™

Live video production has evolved into a new generation of programming. Programs once delivered to a single channel for one-time viewing are now intended for multiple screens, on-demand, online, and social media platforms. With this radical shift, producers answered viewers' expectations to be reached when and where they want to, with the compelling, supplementary content they demand.

Broadcast, live stream, display and record full HD programming with **TriCaster**, a high definition, network-quality portable live

production solution. In one system you gain multi-channel HD switching, HD network-style and holographic virtual sets, HD titling, HD digital disk recording, audio mixing, HD editing, extensive macro and automation functions, full HD streaming, and instant publication on social platforms.

Producers, bloggers, directors, companies or anyone who wants to publish video content worldwide, find in TriCaster all the essential tools to achieve professional results that match their needs.



TriCaster 410



TriCaster 460



TriCaster 860



TriCaster 8000

# TriCaster™ 410



*Optional control surface sold separately - Monitor not included.*

## SDI Multi-Camera Production Tools For Live Delivery

**TriCaster™ 410** is built to create the highest-quality, professional live video projects with SDI cameras, minimal budgets and tight spaces.

The most streamlined of NewTek professional models, TriCaster 410 delivers live to air, display, stream, record, and to social media network, all at the same time. Its mobile, 2U form factor provides uncluttered I/O in any combination of resolutions and frame rates, trims the workflow and the equipment expenditure to fit your live business, and slims down on the postproduction extras.

TriCaster 410 integrates a powerful switcher-effects engine to deliver sophisticated visuals, 3D holographic virtual sets, Mix/effect banks that extend submix and switching capabilities, multi-channel media delivery with simultaneous streaming and social media publishing.



- ✓ **Turnkey Production** - TriCaster 410 replaces gear for recording, encoding, switching, submixing, playback, audio mixing, DVE, advanced graphics and titling, animation store, scan conversion, multiple channels of virtual sets, live streaming, camera automation, scopes and monitors, and social media publishing.
- ✓ **SDI I/O** - Input up to four cameras with varying SD and HD resolutions and formats, correct the color, key, crop, scale, and frame sync. SDI output connections can send the program out to multiple destinations and displays, even to another TriCaster over the network with a network output.
- ✓ **15-channel multi-camera production** - Connectivity for 4 SDI camera sources. 2 DDRs. 2 built-in graphic and sound slots. 2 network sources for sharing computer displays, wireless iOS devices, or any over-the-network source. 4 M/E banks to stage live virtual sets, create real-time compositions and presets, and submixes that can act as upstream switchers.
- ✓ **Audio Mixing** - Unprecedented routing, customization, control and flexibility. Sound configuration and delivery such simulcast audio, multi-language presentation, and mix-minus applications. Full support for mixing from a remote mixer app, the Avid Artist Mix control surface, and other third-party audio control interfaces including LiveMixer.
- ✓ **Holographic LiveSet** - Realistic foregrounds and live moving backgrounds. Take a panoramic of any location with a smart phone, or a 3D model from any universe, and make it your scene using NewTek holographic LiveSet capability, bringing augmented reality that much closer to live. 2 live sources, each with overlay, all with transitions, sounds, 3D DVEs and effects.





# TriCaster™ 410 Technical Specifications

<b>Switcher Channels</b>	15 – 6 external, 5 internal, 4 M/E buses
<b>Video Input</b>	4 simultaneous live video sources over SDI, in any combination of supported resolutions and frame rates (including PsF selections) <ul style="list-style-type: none"> <li>Per-input format configuration, scaler (including 3:2 intelligent pull-down) and frame synchronizer enabling intermixing of formats</li> <li>Per-input color correction, crop and LiveMatte keyer controls</li> <li>Support for Key + Fill input pairing</li> </ul>
<b>Network Sources</b>	2 live inputs via Gigabit connection, selectable from any available network sources with support for video, audio and alpha channel <ul style="list-style-type: none"> <li>Supported sources include networked computers via included NewTek iVGA client application; wireless Apple® AirPlay® devices; TriCaster 8000, 860, 460 or 410; 3Play 4800, 820 or 425; USB video sources; video over IP sources; RTMP or RTSP streams; HTTP streaming video sources; and a variety of third-party partner solutions</li> </ul>
<b>Robotic Camera Support</b>	Access up to 4 live Pan-Tilt-Zoom (PTZ) robotic cameras via standard serial and network protocols, with preset system and user interface control over camera orientation, zoom, focus and iris
<b>Media</b>	4 integrated digital media sources for video, graphics and sounds (2 DDRs, GFX and Sound) + 15 buffers
<b>Buffers</b>	15 still & title buffers, with multiviewer, title editing and presets • Shareable across a network for watch folder application, with real-time edit and update of content
<b>Mix/Effect Buses (M/E)</b>	4 freely configurable M/E channels for video mixing, compositing, effects and virtual sets, each with independent Key layer and support for TransWarp effects <ul style="list-style-type: none"> <li>Mix mode: Enables secondary switcher operation for output, submix or recording, with Program/Preview workflow and transitions</li> <li>Effects mode: Enables multi-layer compositing, effects generation and virtual set application, with per-source 3D DVE, scaling, cropping and keying</li> </ul>
<b>Macros</b>	Record configurations and operation sequences, then attach to keyboard shortcuts, control surface actions, MIDI controllers, or on-screen hotspots for recall and automation <ul style="list-style-type: none"> <li>Macro editor for modifying user-defined macro configurations and sequences</li> <li>Augment and extend TriCaster operation using macro plug-ins to control external devices</li> </ul>
<b>DSKs</b>	2 primary DSK channels, plus 1 additional Key layer per M/E bus, each with independent transition controls, 3D DVE, scaling, cropping and integrated TransWarp effects
<b>Effects and Transitions</b>	Integrated TransWarp effects engine on all effects channels supports standard transitions, customizable animation store transitions with audio, and overlay effects <ul style="list-style-type: none"> <li>Animation Store Creator for custom animations</li> <li>Supports per-pixel alpha blending between sources and real-time 3D warping of video or graphic</li> </ul>
<b>Virtual Sets</b>	30+ HD live virtual sets, with presets, multiple camera angles, real-time reflections, and specular highlights <ul style="list-style-type: none"> <li>Live pan and zoom of virtual camera and customizable virtual camera presets with animated pan, zoom and pedestal moves</li> <li>Support for up to 2 switchable live sources, with per-source 3D DVE, scaling, cropping and keying</li> <li>Supports custom-created virtual sets generated using NewTek Virtual Set Editor or third-party partner solutions</li> </ul>
<b>Holographic Live Virtual Sets</b>	Support for custom virtual environments generated from panoramic smartphone, camera or DSLR images <ul style="list-style-type: none"> <li>Select sets included; custom sets require Virtual Set Editor 2.5</li> </ul>
<b>Hotspots</b>	Up to 8 freely configurable, interactive hotspots per input for macro control
<b>Video Output</b>	Configurable for up to 5 output connections, with support for key output and per-connection signal settings <ul style="list-style-type: none"> <li>2 x SDI</li> <li>HDMI output</li> <li>Network output for live streaming</li> <li>A/V output to network-connected TriCaster over local network</li> </ul>
<b>Recording</b>	Native recording in up to 1080p <ul style="list-style-type: none"> <li>Encoding format selectable from: QuickTime® (XDCAM HD compatible, 4:2:2 encoding, 24-bit audio), MPEG-2 (high or normal profile), AVI (SpeedHQ), and H.264 (high or Web quality)</li> <li>Freely choose to add recordings to Publish queue and DDR destinations</li> </ul>
<b>Grab</b>	Grab full resolution, de-fielded still images from Program output, and freely choose to add grabs to Publish queue, Media Player presets and Buffer destinations

<b>Media Publishing</b>	Supports direct content upload to YouTube™, Facebook, Twitter™, FTP, local or external volumes, and network servers
<b>Live Streaming</b>	HD live streaming with simultaneous archive • Presets in up to 720p, supporting most common streaming profiles and custom multi-bitrate streaming profiles, including RTMP streaming using H.264 (ex. Adobe® Flash® Media Server), Microsoft® Windows Media® Push/Pull, and browser-based streaming applications, with Ustream® and Livestream® native integrated support • Streaming Profile Manager with integrated Web browser
<b>Audio Inputs</b>	4 SDI Embedded - 1 x 2 Balanced XLR (Mic/Line) - 1 x 2 Balanced 1/4" (Mic/Line)
<b>Audio Outputs</b>	2 SDI Embedded - 1 x 2 Balanced XLR - 1 x 2 Balanced 1/4" (AUX) - 1 Stereo 1/4" (phones)
<b>Audio Mixing</b>	Integrated multi-channel audio mixer for internal and external audio sources, outputs, stream and headphones, with 4 fully independent stereo output mixes: 2 Master, 2 AUX • Pan control, solo auditioning, seven-band equalizer and stereo compressor/limiter per input and output, with per-input audio delay control • Multi-bus routing of audio source channels to any combination of outputs, with independent level control over channels 1/2 and 3/4 for quad sources • Audio Follow Video system enabling audio to follow multiple video sources, with support for unlimited audio grouping combinations • Digital audio inputs equipped with audio time-base synchronizers • Supports companion iPad® audio mixing app and Avid® Artist Mix audio control surface
<b>Supported Session Formats</b>	Tricaster 410-MS (Multi-standard): PAL 1080/25p, 1080/24p, 1080/50i, 720/50p, 720/25p, 720/24p, 576/25i; NTSC, NTSC-J 1080/30p, 1080/24p, 1080/60i, 720/60p, 720/30p, 720/24p, 480/60i Tricaster 410 (North America): NTSC 1080/30p, 1080/24p, 1080/60i, 720/60p, 720/30p, 720/24p, 480/60i
<b>Playback Media Formats</b>	AVI, DV, DVCPRO, DVCPROHD, FLV, F4V, H.263, H.264, MOV, MKV, MJPEG, MPEG (1, 2, all profiles, program or transport streams), MP4, WMV, WebM, PSD, PNG, TGA, BMP, JPEG, EXR, RAW, TIF, AIFF, MP3, WAV, and more, with Import Media application for batch import with optional transcoding of files (including Apple ProRes)
<b>Export Media Formats</b>	Export media application for batch copying with optional transcoding of files to compatible formats for different applications and devices: Apple ProRes, AVI, DV, DVCPRO, DVD, H.264, MOV, MPEG-2, MJPEG, MP4, WebM and more
<b>Post Production</b>	NewTek SpeedEDIT 2 non-linear editor available via download for Add-On installation -NewTek SpeedHQ codecs for Mac and PC included for extended file compatibility
<b>Monitoring</b>	DVI and HDMI monitor outputs for user interface and multiview displays - Preview all sources or select sources in a variety of layouts and dual-monitor display combinations via Workspaces control panel - A/V indicator and guide overlays configurable per viewport
<b>Signal Monitoring</b>	Integrated Waveform and Vectorscope, full field rate with digital calibration, color preview and support for ITU-R Rec. 601 and 709
<b>Session Management</b>	Setup and store session settings in reusable template sessions
<b>Processing</b>	Video: 4:4:4:4, 32-bit Floating Point - Audio: 4 channels, 96 kHz, 32-bit Floating Point
<b>A/V Standards</b>	HD-SDI video conforms to SMPTE 292M - SD video conforms to SMPTE 259M and ITU-R BT.656 - Analog audio levels conform to SMPTE RP-155
<b>MIDI Control</b>	Support for standard MIDI protocol enabling third-party MIDI device control of TriCaster operations via macros
<b>System Physical</b>	2U Rack Mount, with 430W power supply and multi-tiered hardware and software fail-safe 48.3 x 8.9 x 54.6 cm (19.0 x 3.5 x 21.5 in)

Subject to change without notice.

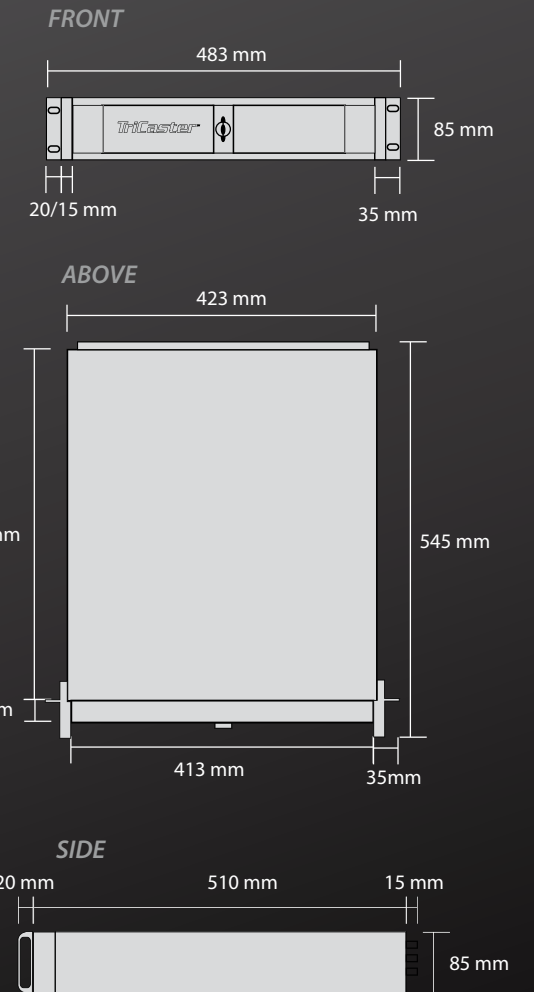

# TriCaster™ 460

## Mobile Production For Engaging Second-Screen Experience

**TriCaster™ 460** The most versatile and extensive of NewTek's mobile-scale multi-camera video solutions, has any-format, any-resolution, any frame-rate I/O and amped-up production capabilities to let you connect any camera, access any available video source, and go live from locations that you could only dream of reaching before. Go live from new worlds with 3D and holographic sets.

Produce a four-camera show, with layered video, real-time compositions, and multiple submixes that give the look of adding four other switchers into the stream. Deliver multi-channel media with simultaneous streaming and social media publishing. Record every feed for later remixing, sweetening, or just fixing mistakes.

Get the source footage to your creative team for postproduction, or create whole new programs from the media you already captured.

✓ **Turnkey Production** - TriCaster 460 multiple turnkey functions, integrated into a small, van-friendly footprint, do the work usually requiring racks of equipment. One system replaces gear for recording, encoding, switching, submixing, playback, audio mixing, DVE, advanced graphics and titling, animation store, scan conversion, multiple channels of virtual sets, live streaming, camera automation, scopes and monitors, and social media publishing.

✓ **4-channel ISO source recording** - NewTek IsoCorder™ technology provides multi-track, multi-format recording of up to four simultaneous channels. Record any combination of your finished show, a clean feed, raw source captures from any camera, at full resolution, directly from the user interface.

✓ **Automation** - Automation functions in TriCaster 460 help you experiment with more complex sequences during a live production. Use macros and create real-time shot sequences. Set up live hotspots, to give the talent the freedom to trigger sequences. Add remotely controlled robotic cameras as input sources, without the need to add camera operators.

✓ **Visual & Motion Effects** - TriCaster 460 has a powerful integrated effects engine. Full-color, animated transitions with alpha channel and embedded audio, real-time cloth dynamics, 3D video warping, and transformations with TransWarp effects and motion overlays. Customize your own, branded effects using the included Animation Store Creator application, and real-time, multi-layered compositions with 4 M/E rows and motion effects.







# TriCaster™ 460 Technical Specifications

<b>Switcher Channels</b>	15 – 6 external, 5 internal, 4 M/E buses
<b>Video Input</b>	4 simultaneous live video sources, in any combination of supported connection types, resolutions and frame rates (including PsF selections) - Direct input of cameras and video devices in any combination of HD-SDI, HD Component, SD-SDI, SD Component, Y/C or Composite connections - Per-input format configuration, scaler (including 3:2 intelligent pull-down) and frame synchronizer enabling intermixing of formats - Per-input color correction, crop and LiveMatte keyer controls - Support for Key + Fill input pairing
<b>Network Sources</b>	2 live inputs via Gigabit connection, selectable from any available network sources with support for video, audio and alpha channel Supported sources include networked computers via included NewTek iVGA client application, wireless Apple® AirPlay® devices, TriCaster 8000, 860, 460 or 410, 3Play 4800, 820 or 425, USB video sources, video over IP sources, RTMP or RTSP streams, HTTP streaming video sources, and a variety of third-party partner solutions
<b>Robotic Camera Support</b>	Access up to 4 live Pan-Tilt-Zoom (PTZ) robotic cameras via standard serial and network protocols, with preset system and user interface control over camera orientation, zoom, focus and iris
<b>Media</b>	4 integrated digital media sources for video, graphics and sounds (2 DDRs, GFX and Sound) + 15 buffers
<b>Buffers</b>	15 content buffers to store and playback video, animations, still images and graphics - 5 animation buffers and 10 still & title buffers, with multiviewer, animation preview, title editing and presets - Shareable across a network for watch folder application, with real-time edit and update of content
<b>Mix/Effect Buses (M/E)</b>	4 freely configurable M/E channels for video mixing, compositing, effects and virtual sets, each with independent Key layer and support for TransWarp effects Mix mode: Enables secondary switcher operation for output, submix or recording, with Program/Preview workflow and transitions Effects mode: Enables multi-layer compositing, effects generation and virtual set application, with per-source 3D DVE, scaling, cropping and keying
<b>Macros</b>	Record configurations and operation sequences, then attach to keyboard shortcuts, control surface actions, MIDI controllers, or on-screen hotspots for recall and automation Macro editor for modifying user-defined macro configurations and sequences - Augment and extend TriCaster operation using macro plug-ins to control external devices
<b>DSKs</b>	2 primary DSK channels, plus 1 additional Key layer per M/E bus, each with independent transition controls, 3D DVE, scaling, cropping and integrated TransWarp effects
<b>Effects and Transitions</b>	Integrated TransWarp effects engine on all effects channels supports standard transitions, customizable animation store transitions with audio, and overlay effects Animation Store Creator for custom animations - Supports per-pixel alpha blending between sources and real-time 3D warping of video or graphics
<b>Virtual Sets</b>	30+ HD live virtual sets, with presets, multiple camera angles, real-time reflections, and specular highlights Live pan and zoom of virtual camera and customizable virtual camera presets with animated pan, zoom and pedestal moves Support for up to 2 switchable live sources, with per-source 3D DVE, scaling, cropping and keying Supports custom-created virtual sets generated using NewTek Virtual Set Editor or third-party partner solutions
<b>Holographic Live Virtual Sets</b>	Support for custom virtual environments generated from panoramic smartphone, camera or DSLR images - Select sets included, custom sets require Virtual Set Editor 2.5
<b>Hotspots</b>	Up to 8 freely configurable, interactive hotspots per input for macro control
<b>Video Output</b>	Configurable for up to 9 output connections, with support for key output and per-connection signal settings 2 x SDI - 2 x Analog (configurable for Component or Y/C + Composite) - HDMI output - Network output for live streaming - A/V output to network-connected TriCaster over local network
<b>Recording</b>	Multi-track, multi-format recording of up to 4 simultaneous channels via IsoCorder™ technology Native recording in up to 1080p with timecode - Encoding format selectable from: QuickTime® (XDCAM HD compatible, 4:2:2 encoding, 24-bit audio), MPEG-2 (high or normal profile), AVI (SpeedHQ), and H.264 (high or Web quality) - Freely choose to add recordings to Publish queue and DDR destinations
<b>Grab</b>	Grab full resolution, de-fielded still images from inputs and outputs, and freely choose to add grabs to Publish queue, Media Player presets and Buffer destinations
<b>Media Publishing</b>	Supports direct content upload to YouTube™, Facebook, Twitter™, FTP, local or external volumes, and network servers
<b>Live Streaming</b>	HD live streaming with simultaneous archive Presets in up to 720p, supporting most common streaming profiles and custom multi-bitrate streaming profiles, including RTMP streaming using H.264 (ex. Adobe® Flash® Media Server), Microsoft® Windows Media® Push/Pull, and browser-based streaming applications, with Ustream® and Livestream® native integrated support Streaming Profile Manager with integrated Web browser

<b>Audio Inputs</b>	4 SDI Embedded - 3 x 2 Balanced 1/4" (Mic/Line) - 1 x 2 Balanced XLR (Mic/Line) - Phantom Power Support
<b>Audio Outputs</b>	2 SDI Embedded - 1 x 2 Balanced XLR - 1 x 2 Balanced 1/4" (AUX) - 1 Stereo 1/4" (phones)
<b>Audio Mixing</b>	Integrated multi-channel audio mixer for internal and external audio sources, outputs, stream and headphones, with 4 fully independent stereo output mixes: 2 Master, 2 AUX Pan control, solo auditioning, seven-band equalizer and stereo compressor/limiter per input and output, with per-input audio delay control Multi-bus routing of audio source channels to any combination of outputs, with independent level control over channels 1/2 and 3/4 for quad sources Audio Follow Video system enabling audio to follow multiple video sources, with support for unlimited audio grouping combinations Digital audio inputs equipped with audio time-base synchronizers Supports companion Live Mixer Add-on, iPad® audio mixing app and Avid® Artist Mix audio control surface
<b>Supported Session Formats</b>	TriCaster 460-MS (Multi-standard): PAL 1080/25p, 1080/24p, 1080/50i, 720/50p, 720/25p, 720/24p, 576/25i, NTSC, NTSC-J: 1080/30p, 1080/24p, 1080/60i, 720/60p, 720/30p, 720/24p, 480/60i TriCaster 460 (North America): NTSC 1080/30p, 1080/24p, 1080/60i, 720/60p, 720/30p, 720/24p, 480/60i
<b>Playback Media Formats</b>	AVI, DV, DVCPRO, DVCPROHD, FLV, F4V, H.263, H.264, MOV, MKV, MJPEG, MPEG (1, 2, all profiles, program or transport streams), MP4, WMV, WebM, PSD, PNG, TGA, BMP, JPEG, EXR, RAW, TIF, AIFF, MP3, WAV, and more, with Import Media application for batch import with optional transcoding of files (including Apple ProRes)
<b>Export Media Formats</b>	Export media application for batch copying with optional transcoding of files to compatible formats for different applications and devices: Apple ProRes, AVI, DV, DVCPRO, DVD, H.264, MOV, MPEG-2, MJPEG, MP4, WebM and more
<b>Post Production</b>	NewTek SpeedEDIT 2 non-linear editor available via download for Add-On installation NewTek SpeedHQ codecs for Mac and PC included for extended file compatibility
<b>Monitoring</b>	DVI and HDMI monitor outputs for user interface and multiview displays Preview all sources or select sources in a variety of layouts and dual-monitor display combinations via Workspaces control panel A/V indicator and guide overlays configurable per viewport
<b>Signal Monitoring</b>	Integrated Waveform and Vectorscope, full field rate with digital calibration, color preview and support for ITU-R Rec. 601 and 709
<b>Session Management</b>	Setup and store session settings in reusable template sessions
<b>Processing</b>	Video: 4:4:4:4, 32-bit Floating Point Audio: 4 channels, 96 kHz, 32-bit Floating Point
<b>A/V Standards</b>	HD-SDI video conforms to SMPTE 292M SD video conforms to SMPTE 259M and ITU-R BT.656 Analog audio levels conform to SMPTE RP-155
<b>Control Surface</b>	Optional TriCaster 460 hardware control surface Surface ~ 23.5 x 0.5 x 11.6 in (59.7 x 1.3 x 29.5 cm) Base ~ 22.5 x 2.0 x 10.8 in (57.2 x 5.1 x 27.4 cm) 14.6 lbs (6.6 kg)
<b>MIDI Control</b>	Support for standard MIDI protocol enabling third-party MIDI device control of TriCaster operations via macros
<b>System Physical</b>	2U Rack Mount, with 430W power supply and multi-tiered hardware and software fail-safe 48.3 x 8.9 x 54.6 cm (19.0 x 3.5 x 21.5 in) 11.8 kg (26 lbs)

Subject to change without notice.

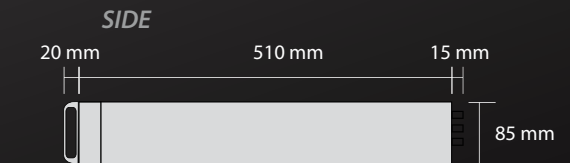
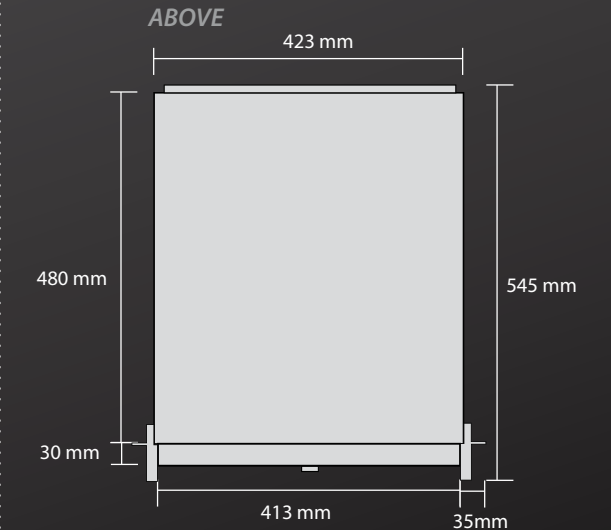
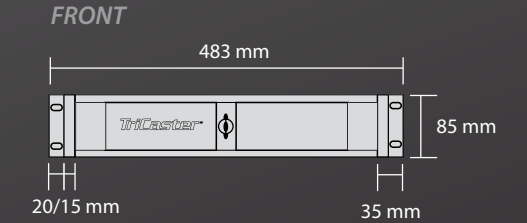



# TriCaster™ 860



*Optional control surface sold separately - Monitor not included.*

## Complete Live Production Solution To Invent Your Own Media Strategy

**TriCaster™ 860** is a multi-camera production platform that was designed with content creation goals in mind. Create new strategies for video, communication, and social media that make continued use of your most valuable assets: video content.

TriCaster 860 builds on the features of every TriCaster professional model, and adds more channels, more sources, more I/O, more visuals and effects, and higher capacity. Add new shows or take on more clients, create more programming, and discover fresh streams of revenue from the same program content. With a fully loaded, 24-channel switcher with 8 M/Es, eight-source ISO recording, real-time multi-channel media delivery with simultaneous streaming and social media publishing, and the integrated effects system, live productions will be explosive.

✓ **Mix-and-Match I/O** - TriCaster 860 provides connectivity to prepare for any location scenario. Connect up to 8 cameras with the capability to mix and match connection types, including SDI, component, composite and Y/C, and even camera types with varying SD and HD resolutions and formats. Up to 11 output connections and 2 independent A/V output connections can send the program out to multiple destinations and displays, even to another TriCaster.

✓ **24-channel multi-camera production** - With the 24 channel, multi-camera TriCaster 860, nearly every possible live and stored source are at your fingertips. Up to 8 cameras in any HD and SD configuration. 2 digital media players for video clips. 3 slots for graphics, titles and sounds. 2 network channels. 8 M/E banks.

✓ **Buffers and Network Inputs** - Instant access to more content in real time. 10 still buffers and 5 animation buffers provide 15 bonus "always on" sources. Enhanced network inputs support cloud video, streaming servers, remote cameras, remotely hosted clips, USB cameras and more.

✓ **Failsafe & Redundancy** - TriCaster 860 provides multi-tiered redundant failsafe mechanisms in both hardware and software. Redundant, removable power supplies and hot-swappable hard drives.

✓ **Capacity** - Capacity of 200 hours in HD. 5 integrated digital media players are on-hand to augment the production, on top of 10 live and 8 virtual sources. Use the session library to save settings and assets for each production.





# TriCaster™ 860 Technical Specifications

<b>Switcher Channels</b>	24 - 10 external, 6 internal, 8 M/E buses
<b>Video Input</b>	8 simultaneous live video sources, in any combination of supported connection types, resolutions and frame rates (including PsF selections) Direct input of cameras and video devices in any combination of HD-SDI, HD Component, SD-SDI, SD Component, Y/C or Composite connections Per-input format configuration, scaler (including 3:2 intelligent pull-down) and frame synchronizer enabling intermixing of formats Per-input color correction, crop and LiveMatte keyer controls Support for Key + Fill input pairing
<b>Network Sources</b>	2 live inputs via Gigabit connection, selectable from any available network sources with support for video, audio and alpha channel Supported sources include networked computers via included NewTek iVGA client application, wireless Apple® AirPlay® devices, TriCaster 8000, 860, 460 or 410, 3Play 4800, 820 or 425, USB video sources, video over IP sources, RTMP or RTSP streams, HTTP streaming video sources, and a variety of third-party partner solutions
<b>Robotic Camera Support</b>	Access up to 8 live Pan-Tilt-Zoom (PTZ) robotic cameras via standard serial and network protocols, with preset system and user interface control over camera orientation, zoom, focus and iris
<b>Media</b>	5 integrated digital media sources for video, graphics and sounds (2 DDRs, 2 GFX and Sound) + 15 buffers
<b>Buffers</b>	15 content buffers to store and playback video, animations, still images and graphics 5 animation buffers and 10 still & title buffers, with multiviewer, animation preview, title editing and presets Shareable across a network for watch folder application, with real-time edit and update of content
<b>Mix/Effect Buses (M/E)</b>	8 freely configurable M/E channels for video mixing, compositing, effects and virtual sets, each with independent Key layer and support for TransWarp effects Mix mode: Enables secondary switcher operation for output, submix or recording, with Program/Preview workflow and transitions Effects mode: Enables multi-layer compositing, effects generation and virtual set application, with per-source 3D DVE, scaling, cropping and keying
<b>Macros</b>	Record configurations and operation sequences, then attach to keyboard shortcuts, control surface actions, MIDI controllers, or on-screen hotspots for recall and automation Macro editor for modifying user-defined macro configurations and sequences Augment and extend TriCaster operation using macro plug-ins to control external devices
<b>DSKs</b>	2 primary DSK channels, plus 1 additional Key layer per M/E bus, each with independent transition controls, 3D DVE, scaling, cropping and integrated TransWarp effects
<b>Effects and Transitions</b>	Integrated TransWarp effects engine on all effects channels supports standard transitions, customizable animation store transitions with audio, and overlay effects Animation Store Creator for custom animations Supports per-pixel alpha blending between sources and real-time 3D warping of video or graphics
<b>Virtual Sets</b>	30+ HD live virtual sets, with presets, multiple camera angles, real-time reflections, and specular highlights Live pan and zoom of virtual camera and customizable virtual camera presets with animated pan, zoom and pedestal moves Support for up to 2 switchable live sources, with per-source 3D DVE, scaling, cropping and keying Supports custom-created virtual sets generated using NewTek Virtual Set Editor or third-party partner solutions
<b>Holographic Live Virtual Sets</b>	Support for custom virtual environments generated from panoramic smartphone, camera or DSLR images Select sets included, custom sets require Virtual Set Editor 2.5
<b>Hotspots</b>	Up to 8 freely configurable, interactive hotspots per input for macro control
<b>Video Output</b>	Configurable for up to 12 output connections, with support for key output and per-connection signal settings 3 x SDI - 3 x Analog (configurable for Component or Y/C + Composite) - HDMI output - Network output for live streaming - A/V output to network-connected TriCaster over local network
<b>Recording</b>	Multi-track, multi-format recording of up to 8 simultaneous channels via IsoCorder™ technology - Native recording in up to 1080p with timecode - Encoding format selectable from: QuickTime® (XDCAM HD compatible, 4:2:2 encoding, 24-bit audio), MPEG-2 (high or normal profile), AVI (SpeedHQ), and H.264 (high or Web quality) - Freely choose to add recordings to Publish queue and DDR destinations
<b>Grab</b>	Grab full resolution, de-fielded still images from inputs and outputs, and freely choose to add grabs to Publish queue, Media Player presets and Buffer destinations

<b>Media Publishing</b>	Supports direct content upload to YouTube™, Facebook, Twitter™, FTP, local or external volumes, and network servers
<b>Live Streaming</b>	HD live streaming with simultaneous archive - Presets in up to 720p, supporting most common streaming profiles and custom multi-bitrate streaming profiles, including RTMP streaming using H.264 (ex. Adobe® Flash® Media Server), Microsoft® Windows Media® Push/Pull, and browser-based streaming applications, with Ustream® and Livestream® native integrated support - Streaming Profile Manager with integrated Web browser
<b>Audio Inputs</b>	8 SDI Embedded - 8 AES3/EBU - 8 x 2 Balanced XLR (Mic/Line) - Phantom Power Support
<b>Audio Outputs</b>	3 SDI Embedded - 2 AES3/EBU - 4 Balanced XLR - 4 Balanced XLR (AUX) - 1 Stereo 1/4" (phones)
<b>Audio Mixing</b>	Integrated multi-channel audio mixer for internal and external audio sources, outputs, stream and headphones, with 4 fully independent stereo output mixes: 2 Master, 2 AUX Pan control, solo auditioning, seven-band equalizer and stereo compressor/limiter per input and output, with per-input audio delay control Multi-bus routing of audio source channels to any combination of outputs, with independent level control over channels 1/2 and 3/4 for quad sources AFV system enabling audio to follow multiple video sources, with support for unlimited audio grouping combinations Digital audio inputs equipped with audio time-base synchronizers Supports companion Live Mixer Add-on, iPad® audio mixing app and Avid® Artist Mix audio control surface
<b>Supported Session Formats</b>	TriCaster 860-MS (Multi-standard): PAL 1080/25p, 1080/24p, 1080/50i, 720/50p, 720/25p, 720/24p, 576/25i, NTSC, NTSC-J: 1080/30p, 1080/24p, 1080/60i, 720/60p, 720/30p, 720/24p, 480/60i TriCaster 860 (North America): NTSC 1080/30p, 1080/24p, 1080/60i, 720/60p, 720/30p, 720/24p, 480/60i
<b>Playback Media Formats</b>	AVI, DV, DVCPRO, DVCPROHD, FLV, F4V, H.263, H.264, MOV, MKV, MJPEG, MPEG (1, 2, all profiles, program or transport streams), MP4, WMV, WebM, PSD, PNG, TGA, BMP, JPEG, EXR, RAW, TIF, AIFF, MP3, WAV, and more, with Import Media application for batch import with optional transcoding of files (including Apple ProRes)
<b>Export Media Formats</b>	Export media application for batch copying with optional transcoding of files to compatible formats for different applications and devices: Apple ProRes, AVI, DV, DVCPRO, DVD, H.264, MOV, MPEG-2, MJPEG, MP4, WebM and more
<b>Post Production</b>	NewTek SpeedEDIT 2 non-linear editor available via download for Add-On installation NewTek SpeedHQ codecs for Mac and PC included for extended file compatibility
<b>Monitoring</b>	DVI and HDMI monitor outputs for user interface and multiview displays Preview all sources or select sources in a variety of layouts and dual-monitor display combinations via Workspaces control panel A/V indicator and guide overlays configurable per viewport
<b>Signal Monitoring</b>	Integrated Waveform and Vectorscope, full field rate with digital calibration, color preview and support for ITU-R Rec. 601 and 709
<b>Session Management</b>	Setup and store session settings in reusable template sessions
<b>Processing</b>	Video: 4:4:4:4, 32-bit Floating Point - Audio: 4 channels, 96 kHz, 32-bit Floating Point
<b>A/V Standards</b>	HD-SDI video conforms to SMPTE 292M - SD video conforms to SMPTE 259M and ITU-R BT.656 - Analog audio levels conform to SMPTE RP-155
<b>Control Surface</b>	Optional TriCaster 860 hardware control surface - Surface ~ 28.5 x 0.5 x 11.6 in (72.4 x 1.3 x 29.5 cm) - Base ~ 27.5 x 2.0 x 10.8 in (69.9 x 5.1 x 27.4 cm) 18.1 lbs (8.2 kg)
<b>MIDI Control</b>	Support for standard MIDI protocol enabling third-party MIDI device control of TriCaster operations via macros
<b>System Physical</b>	4U Rack Mount, with 550W power supply and multi-tiered hardware and software fail-safe 48.3 x 17.8 x 52 cm (19.0 x 7 x 20.5 in) 20 kg (44 lbs)

Subject to change without notice.

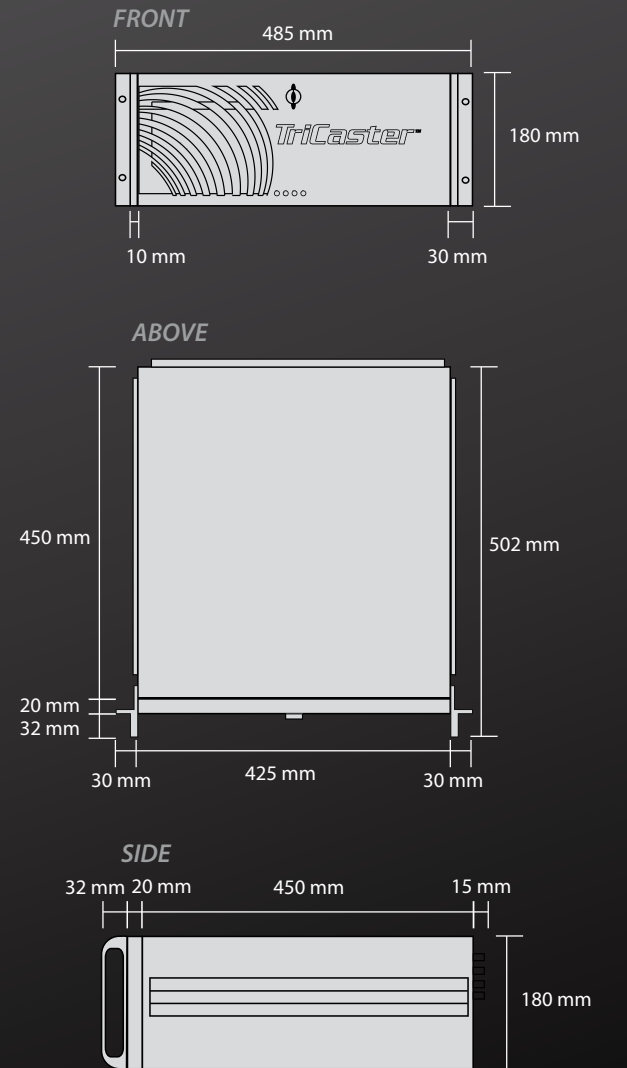



NEW  
VERSION  
2013

PRODUCT

NewTek

# TriCaster™ 8000

## Complete Live Production and Media Publishing Solution

**TriCaster™ 8000** is the first live television production platform that allows producers to create multi-camera video programs for live events, broadcasting, web streaming, and projection, while simultaneously publishing clips and stills to social media networks.

The system introduces extensive integration and customization options that include third-party router support, recordable macros that can be triggered simultaneously, along with extensive effects and graphics capabilities with eight M/E rows.

TriCaster 8000 includes a social media “Share” panel that allows for video clips, individual stills, or batches of ISO-grabbed frames of the live show to be distributed to multiple social media platforms, including Facebook, YouTube, Twitter, and Flickr, or to an FTP server.

- ✓ **Enterprise Integration** - Add router control to multiply camera sources and deliver to more outputs without conversion with GVNP protocol integrated, look even bigger with multi-input virtual sets, or downsize for a small-scale show, seamlessly. The API support, offers the potential for external control of almost anything in the switcher.
- ✓ **Custom Configuration** - Freely configure up to four monitors, create complex sequences with one-button macros. Customize sets, transitions, and effects to allow every facility and operator to create their own brand, production or studio environment.
- ✓ **Social Media Integration** - Easily publish, share and distribute content to multiple social media sites, even during live production, to instantly engage your fans and followers.
- ✓ **Monumental Effects and Graphics Capabilities** - A full palette of creative tools like warping video, 3D production, and 8 M/E rows to create dramatic visual effects.
- ✓ **Mirroring** - Mirroring of a second TriCaster 8000 system fulfills broadcasters' requirement for redundancy. Sync with an identically setup TriCaster 8000 system in order to continue to ride through a program seamlessly.



Monitor not included.



# TriCaster™ 8000 Technical Specifications

<b>Switcher Channels</b>	24 - 10 external, 6 internal, 8 M/E buses
<b>Video Input</b>	8 simultaneous live video sources, in any combination of supported connection types, resolutions and frame rates (including PsF selections), with third-party video router support Direct input of cameras and video devices in any combination of HD-SDI, HD Component, SD-SDI, SD Component, Y/C or Composite connections Compatible external video routers include brands supporting Grass Valley® Native Protocol, AJA® KUMO and Blackmagic Design® Video Hub Per-input format configuration, scaler (including 3:2 intelligent pull-down) and frame synchronizer enabling intermixing of formats Per-input color correction, crop and LiveMatte keyer controls Support for Key + Fill input pairing
<b>Network Sources</b>	2 live inputs via Gigabit connection, selectable from any available network sources with support for video, audio and alpha channel Supported sources include networked computers via included NewTek iVGA client application: wireless Apple® AirPlay® devices, TriCaster 8000, 860, 460 or 410n, 3Play 4800, 820 or 425, USB video sources, video over IP sources, RTMP or RTSP streams, HTTP streaming video sources, and a variety of third-party partner solutions
<b>Robotic Camera Support</b>	Access up to 8 live Pan-Tilt-Zoom (PTZ) robotic cameras via standard serial and network protocols, with preset system and user interface control over camera orientation, zoom, focus and iris
<b>Media</b>	5 integrated digital media sources for video, graphics and sounds (2 DDRs, 2 GFX and Sound) + 15 buffers
<b>Buffers</b>	15 content buffers to store and playback video, animations, still images and graphics - 10 animation buffers and 5 still & title buffers, with multiviewer, animation preview, title editing and presets - Shareable across a network for watch folder application, with real-time edit and update of content
<b>Mix/Effect Buses (M/E)</b>	8 freely configurable M/E channels with re-entry for video mixing, compositing, effects, real-time motion tracking and virtual sets, each with 4 independent Key layers and support for TransWarp effects - Mix mode: Enables secondary switcher operation for output, submix or recording, with Program/Preview workflow and transitions - Effects mode: Enables multi-layer compositing, effects generation and virtual set application, with per-source 3D DVE, scaling, cropping, edge feathering and keying
<b>Macros</b>	Record configurations and operation sequences, then attach to keyboard shortcuts, control surface actions, MIDI controllers, or on-screen hotspots for recall and automation - Macro editor for modifying user-defined macro configurations and sequences - Augment and extend TriCaster operation using macro plug-ins to control external devices
<b>DSKs</b>	4 primary DSK channels, plus 4 additional Key layer per M/E bus, each with independent transition controls, 3D DVE, edge feathering, scaling, cropping and integrated TransWarp effects
<b>Effects and Transitions</b>	Integrated TransWarp effects engine on all effects channels supports standard transitions, customizable animation store transitions with audio, and overlay effects - Animation Store Creator for custom animations - Supports per-pixel alpha blending between sources and real-time 3D warping of video or graphics
<b>Virtual Sets</b>	30+ HD live virtual sets, with presets, multiple camera angles, real-time reflections, and specular highlights - Live pan and zoom of virtual camera and customizable virtual camera presets with animated pan, zoom and pedestal moves - Support for up to 4 switchable live sources and multi-box effects, with per-source 3D DVE, edge feathering, scaling, cropping and keying Supports custom-created virtual sets generated using NewTek Virtual Set Editor or third-party partner solutions
<b>Holographic Live Virtual Sets</b>	Support for custom virtual environments generated from panoramic smartphone, camera or DSLR images - Select sets included, custom sets require Virtual Set Editor 2.5
<b>Hotspots</b>	Up to 8 freely configurable, interactive hotspots per input for macro control
<b>Video Output</b>	Configurable for up to 14 output connections, with support for key output and per-connection signal settings - 3 x SDI - 3 x Analog (configurable for Component or Y/C + Composite) HDMI output - 2 x VGA (VGA and VGA over HDMI) for additional displays or projectors - Network output for live streaming - A/V output to network-connected TriCaster over local network
<b>Recording</b>	Multi-track, multi-format recording of up to 8 simultaneous channels via IsoCorder™ technology - Native recording in up to 1080p with timecode Encoding format selectable per source: QuickTime® (XDCAM HD compatible, 4:2:2 encoding, 24-bit audio), MPEG-2 (high or normal profile), AVI (SpeedHQ), and H.264 (high or Web quality) - Freely choose to add recordings to Publish queue and DDR destinations
<b>Grab</b>	Grab full resolution, de-fielded still images from all inputs and outputs, and freely choose to add grabs to Publish queue, Media Player presets and Buffer destinations
<b>Media Publishing</b>	Supports direct content upload to YouTube™, Facebook, Twitter™, FTP, local or external volumes, and network servers

<b>Live Streaming</b>	HD live streaming with simultaneous archive - Presets in up to 720p, supporting most common streaming profiles and custom multi-bitrate streaming profiles, including RTMP streaming using H.264 (ex. Adobe® Flash® Media Server), Microsoft® Windows Media® Push/Pull, and browser-based streaming applications, with Ustream® and Livestream® native integrated support - Streaming Profile Manager with integrated Web browser
<b>Audio Inputs</b>	8 SDI Embedded - 8 AES3/EBU - 8 x 2 Balanced XLR (Mic/Line) - Phantom Power Support
<b>Audio Outputs</b>	3 SDI Embedded - 2 AES3/EBU - 4 Balanced XLR - 4 Balanced XLR (AUX) - 1 Stereo 1/4" (phones)
<b>Audio Mixing</b>	Integrated multi-channel audio mixer for internal and external audio sources, outputs, stream and head-phones, with 4 fully independent stereo output mixes: 2 Master, 2 AUX Pan control, solo auditioning, seven-band equalizer and stereo compressor/limiter per input and output, with per-input audio delay control Multi-bus routing of audio source channels to any combination of outputs, with independent level control over channels 1/2 and 3/4 for quad sources AFV system enabling audio to follow multiple video sources, with support for unlimited audio grouping combinations Digital audio inputs equipped with audio time-base synchronizers Supports companion Live Mixer Add-on, iPad® audio mixing app and Avid® Artist Mix audio control surface
<b>Supported Session Formats</b>	Tricaster 8000-MS (Multi-standard): PAL 1080/25p, 1080/24p, 1080/50i, 720/50p, 720/25p, 720/24p, 576/25i, NTSC, NTSC-J 1080/30p, 1080/24p, 1080/60i, 720/60p, 720/30p, 720/24p, 480/60i Tricaster 8000 (North America): NTSC 1080/30p, 1080/24p, 1080/60i, 720/60p, 720/30p, 720/24p, 480/60i
<b>Playback Media Formats</b>	AVI, DV, DVCPRO, DVCPROHD, FLV, F4V, H.263, H.264, MOV, MKV, MJPEG, MPEG (1, 2, all profiles, program or transport streams), MP4, WMV, WebM, PSD, PNG, TGA, BMP, JPEG, EXR, RAW, TIF, AIFF, MP3, WAV, and more, with Import Media application for batch import with optional transcoding of files (including Apple ProRes)
<b>Export Media Formats</b>	Export media application for batch copying with optional transcoding of files to compatible formats for different applications and devices: Apple ProRes, AVI, DV, DVCPRO, DVD, H.264, MOV, MPEG-2, MJPEG, MP4, WebM and more
<b>Post Production</b>	NewTek SpeedEDIT 2 non-linear editor available via download for Add-On installation - NewTek SpeedHQ codecs for Mac and PC included for extended file compatibility
<b>Monitoring</b>	DVI monitor outputs for user interface and multiview preview displays - Preview all sources or select sources in a variety of layouts and dual-monitor display combinations via Workspaces control panel - Viewports freely configurable for any combination of input sources, Program, Preview, M/E buses, clocks or images - A/V indicator and guide overlays configurable per viewport
<b>Signal Monitoring</b>	Integrated Waveform and Vectorscope, full field rate with digital calibration, color preview and support for ITU-R Rec. 601 and 709
<b>Mirroring</b>	Redundant operation and synchronized control supported between TriCaster 8000 systems connected to the same local network
<b>Session Management</b>	Setup and store session settings in reusable template sessions
<b>Processing</b>	Video: 4:4:4:4, 32-bit Floating Point - Audio: 4 channels, 96 kHz, 32-bit Floating Point
<b>A/V Standards</b>	HD-SDI video conforms to SMPTE 292M - SD video conforms to SMPTE 259M and ITU-R BT.656 - Analog audio levels conform to SMPTE RP-155
<b>Control Surface</b>	Includes TriCaster 8000 hardware control surface - Surface ~ 34.1 x 1.0 x 13.8 in (86.6 x 2.6 x 35.1 cm) - Base ~ 34.1 x 2.2 x 12.8 in (86.6 x 5.6 x 32.5 cm)
<b>MIDI Control</b>	Support for standard MIDI protocol enabling third-party MIDI device control of TriCaster operations via macros
<b>System Physical</b>	4U Rack Mount, with 550W redundant, removable power supply and multi-tiered hardware and software fail-safe - 48.3 x 17.8 x 52.0 cm (19.0 x 7.0 x 20.5 in) - 20 kg (44 lbs)

Subject to change without notice.

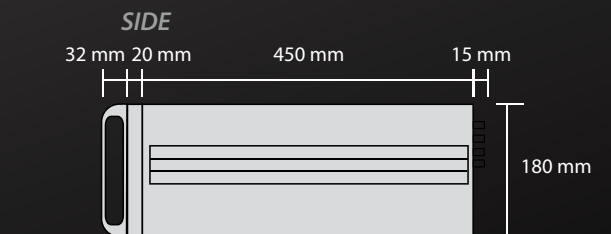
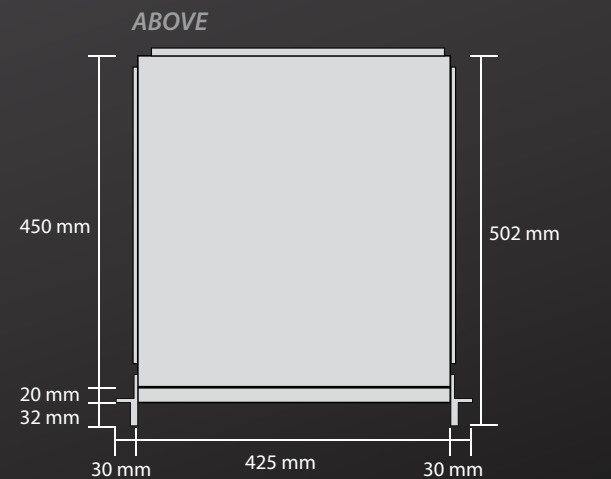



# Control Surfaces

## TriCaster™ 8000 CS



**TriCaster™ 8000 CS** is a natural extension of the platform's remarkable innovation, with a user-focused, industrial design and fresh, new take on familiar production controls. With the integration of TriCaster 8000 CS to your workflow, have a seamless, physical connection to the powerful capabilities of TriCaster 8000, with a whole new dimension of speed and control.

## TriCaster™ 860 CS



**TriCaster™ 860 CS** - With an intuitive layout mapped directly to TriCaster 860 interface for maximum interaction, adding TriCaster 860 CS to your control room or live truck offers a seamless, simultaneous changeover of multiple production elements with versatile, multi-select delegate controls. *TriCaster 860 CS is also backwards compatible with TriCaster 855, 850 EXTREME and 850 models.*

## TriCaster™ 460 CS



**TriCaster™ 460 CS**, part of the complete TriCaster 460 and 410 solutions, maintains a small production footprint without sacrificing manual control. With an intuitive layout, familiar live production controls and compact frame, TriCaster 460 CS is a perfect fit for mobile production or tight spaces. *TriCaster 460 CS is also backwards compatible with TriCaster 455, 450 EXTREME and 450 models.*

## TriCaster™ 40 CS



Designed for the TriCaster 40 system, **TriCaster™ 40 CS** adds fast, full access to hardware operation of all live-production functions of the TriCaster 40. Augment your crew with an additional operator, and split the tasks between console and user interface. Within its possibilities and when it comes to portability the 40 CS is also the most compact control surface to operate a TriCaster 410, 460, 860 and 8000 in a confined space.

## TriCaster™ 850 TW



**TriCaster™ 850 TW** gives control over all media playback capabilities, including one channel instant replay. This flexible control surface provides normal and fast jog modes, a T-bar for dynamic speed replay, preset buttons, mark-in, mark-out controls to select clips. Share the workload with a second operator, focused exclusively on playing back stored clips and graphics. *TriCaster 850 TW is compatible with TriCaster 8000, 860, 460, 410 and 40 models. TriCaster 850 TW is also backwards compatible with TriCaster 855, 455, 850 series, 450 series and 300 models.*



# Software

## Virtual Set Editor 2.5

Transform any location into a professional, virtual environment that raises your production value, and upgrade your presentation with amazing visual effects that make a big impression on your audience.

With **Virtual Set Editor™**, customizable sets for TriCaster support up to four live video sources at the same time, scaled, rotated, even mapped to 3D shapes, and realistic camera movements in 3D space.

**Virtual Set Editor** includes Animation Store Creator with the powerful TransWarp effects engine. Virtual sets can be customized with full-color, animated transitions with alpha channel and embedded audio. Add real-time cloth dynamics, warped animated 3D effects and transformations, or motion overlays.

**Holographic LiveSets**, create a custom 3D environment from any real-world location, transforming a panoramic image taken with a smartphone into a photorealistic, holographic live virtual set.



## LiveText 2

**LiveText 2™** allows to easily create and update titles and graphics on-the-fly during live production. Connected to TriCaster via an Ethernet connection, the HD/SD multi-def titling software easily displays real-time data, scores, times, and other fast-changing information during fast-pace production.

LiveText 2 gives the ability to share the workload and adds flexibility in your production. Whether preparing a large number of titles in pre-production on a laptop off-site or making last minute changes during the show, LiveText makes your production run fast and smooth.

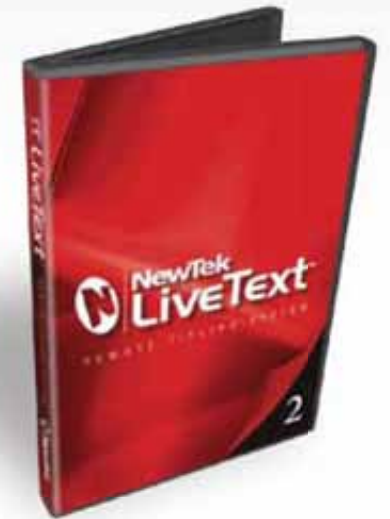

## SpeedEDIT

**SpeedEDIT™** is a resolution-independent video editor designed to work efficiently on any project. Get real-time up and down conversion, 3D position, size and rotation, interpolated slow motion. Support various resolution HD and SD on the same timeline and multi formats conversion in the same project.



# 3Play™

**3Play™** product line is what producers were waiting for, powerful and affordable replay systems! All kinds of Sport events can now be broadcasted in slow motion, key element to appreciate and highlight a production. 3Play gives

operators the ability to capture the action on every camera, to automatically archive the same action from various angles. Therefore, the director still has all his cameras angle shots for any selected action.



3Play™ 4800



3Play™ 425

**NEW  
PRODUCT  
2013**

PRODUCT

**NewTek**

# 3Play™ 4800



## A Price Performance Breakthrough in Live Sports Production

**3Play™ 4800**, a multi-camera replay server that redefines price/performance standards in live sports production, with up to 8 simultaneous live video sources, or up to 4 with fully redundant capture. The new system, offers more real-time capabilities than any other multi-camera replay server, and gives sports producers unprecedented access to redundant capture, sophisticated visual effects, live replay switching, high quality slow motion, and social media publishing, all within a single, turnkey system.

✓ **Redundant Capture** - Redundant capture of up to 4 live video sources doubles up ISO recordings and protects all media assets. Users can also choose to simultaneously record all 8 inputs as separate camera feeds to add more angles as needed.

✓ **High-end Visuals** - Live animated, 3D-warped visual transition effects for switching and in-program editing, with custom animation creator and import of your own branded graphic elements.

✓ **Live Replay Switching** - Monitor all angles during replay, and transition between them video-switcher style, providing a completely finished replay segment within moments, animated transitions and all, to output to switcher, feed the video board, or upload to the Web.

✓ **High Quality Slow Motion** - Get clear, crisp slow motion playback with both standard HD or SD cameras, for sharper slow motion and dramatic stills alike.

✓ **Social Media Publishing** - Easily distribute content to multiple social media sites in one pass, even during live production, for a unified, immediate brand presence.







# 3Play™ 4800 Technical Specifications

<b>Video Input</b>	Up to 8 simultaneous live video sources, or up to 4 with fully redundant capture, in any combination of HD-SDI, HD Component, SD-SDI, SD Component, Y/C (BNC) or Composite connections and resolutions
<b>Video Output</b>	2 fully independent playout channels - Primary outputs individually configurable as HD-SDI, HD Component, SD-SDI, SD Component, or Y/C (BNC) plus Composite - Supplemental HDMI output - Ethernet connection for output of playout channels over a local network to TriCaster
<b>Output Modes</b>	A; B; A+B with transitions between playout channels
<b>Recording</b>	8 simultaneous recording channels - Standard mode captures 8 live video sources - Redundant mode captures 4 live video sources, with 4 channels of simultaneous backup recording
<b>Recording Format</b>	Native recording up to 1080p resolution in high-quality QuickTime format (XDCAM-HD at 100Mbps)
<b>Recording Capacity</b>	Accommodates ~200 hours 1080i or ~1200 480i via 4 removable 2TB media drives (included) - 4 trayless SATA III removable drive bays with hot-swap support for unlimited storage and backup - Simultaneous recording of 2 channels per media drive
<b>Playback</b>	Multi-speed playback via T-Bar or transport buttons - Dual range modes for 0% to 100% playback speed or -200% to 200% playback speed (supports fast reverse)
<b>Grab</b>	Grab still images from all inputs simultaneously
<b>Media Publishing</b>	Integrated application for content upload to YouTube, Facebook, Twitter, FTP, local volumes, or network servers
<b>Effects and Transitions</b>	Standard transitions and customizable animation store transitions supported for transitioning between playout channels and playlist clips - Animation Store Creator application included for custom transitions and effects - Integrated TransWarp effects engine supports per-pixel alpha blending between sources, real-time 3D warping of video or graphics, and embedded audio
<b>Asset Management</b>	- FastClip information window displays asset data and collects keyboard and control surface input for data entry, editing, navigation, search and management - Tags system to enter and organize metadata via user-defined codes - Bookmarks to define and transport to action points
<b>Monitoring</b>	- Resizable, full field rate preview monitors for all live sources and playout channels, with optional overlays for audio VU meters and safe areas - Clip Monitors to preview all angles of a recorded event simultaneously in the Clip List or Multi-Viewer display
<b>Multi-Viewer</b>	Supported with 2nd display, including playback data

<b>Audio Inputs</b>	8 SDI Embedded 8 AES3/EBU 8 x 2 Balanced XLR Phantom Power Support
<b>Audio Outputs</b>	3 SDI Embedded 2 AES3/EBU 4 x 2 Balanced XLR 1 Stereo 1/4" (phones)
<b>Genlock</b>	Locks to HD or SD analog signals - Supports either tri-level or bi-level sync sources
<b>Video Formats</b>	3Play 4800-MS (Multi-standard): PAL 1080/25p, 1080/50i, 720/50p, 720/25p, 576/25i, NTSC, NTSC-J: 1080/30p, 1080/24p, 1080/60i, 720/60p, 720/30p, 720/24p, 480/60i 3Play 4800 (North America): NTSC 1080/30p, 1080/24p, 1080/60i, 720/60p, 720/30p, 720/24p, 480/60i
<b>Session Management</b>	Setup and store session settings in reusable template sessions
<b>Time Code</b>	External LTC source or internal system clock
<b>Processing</b>	Video: 4:4:4:4, 32-bit Floating Point Audio: 4 channels, 96 kHz, 32-bit Floating Point
<b>A/V Standards</b>	HD-SDI video conforms to SMPTE 292M SD video conforms to SMPTE 259M and ITU-R BT.656 Analog audio levels conform to SMPTE RP-155
<b>Controller</b>	Includes 3Play 4800 hardware control surface - 12.7 W x 5.9 H x 13.8 D in (32.3 W x 15.0 H x 35.1 D cm) - 7.5 lbs (3.4 kg)
<b>System Physical</b>	4U Rack Mount, with 550W redundant, removable power supply and multi-tiered hardware and software fail-safe - 19.0 x 7.0 x 20.5 in (48.3 x 17.8 x 52.0 cm) - 44 lbs (20 kg)

Subject to change without notice.

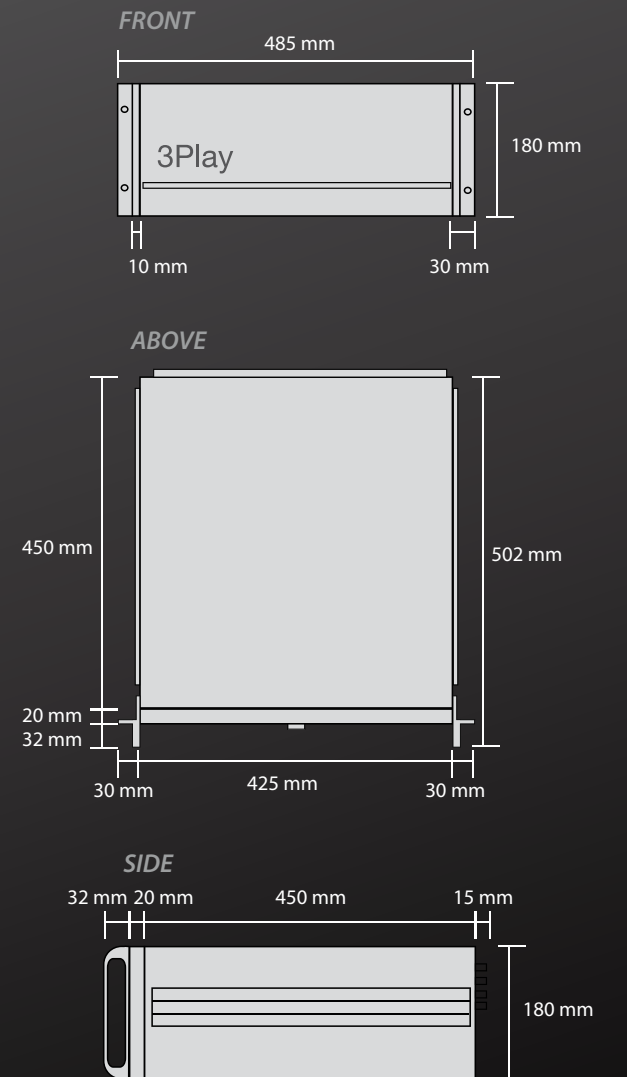

# 3Play™ 425



## Replay in Compact Version

**3Play™ 425**, a 6-channel (four-in, two-out), slow motion system, includes proprietary NewTek IsoCorder™ technology which provides the simultaneous display, recording, and instant replay of up to four video streams, each with audio.

- ✓ **Big-game Capability** - Providing six-channel with four cameras inputs to live sports producers, and two fully independent channels out, 3Play 425 gets you the professional, multi-camera replay coverage you've been aiming for, without going over the cap.
- ✓ **Booth and Van-friendly** - From mobile unit, to press booth, the sleek 3Play 425 network-quality replay slides easily into any existing production space or produce from places you've never been able to before.
- ✓ **Multi-game Workflow** - 30 hours of recording capacity, plus removable storage to bring drive after drive off the bench when marathon recording is a must. Session management lets you keep games and clips organized. And,

built-in applications allow for importing and exporting media to handle any in-game or post-game file requirements.

- ✓ **Show-stopping Slow Motion** - Network-style presentation with smooth, interpolated slow motion. Break down highlights or analyze pivotal moments, frame by frame, and with incredible detail.
- ✓ **In-game Highlights** - Build highlight or sponsor blocks at great speed for instant replay on command, during timeouts, or going into a break. Package the best plays, critical mistakes, and monumental moments together, and then add transitions and background sound for a strong finish.
- ✓ **Standalone and Switcher-friendly** - By itself, connected to your existing production setup, or teamed up with TriCaster over a local network, 3Play 425 plays well with others. Plug in 3Play to multiply the inputs of your switcher, streamline your entire operation with the NewTek live sports systems and have a complete, integrated live production solution using a fraction of the space and with unmatched mobility.







# 3Play™ 425 Technical Specifications

<b>Video Inputs</b>	4 simultaneous inputs Any combination of: HD-SDI, HD Component, SD-SDI, SD Component, Composite, or Y/C (BNC)
<b>Video Outputs</b>	2 fully independent, simultaneous playout channels HD-SDI, HD Component, SD-SDI, SD Component, Composite, or Y/C (BNC) HDMI output Dedicated HDMI multi-view output Network output for over-the-network input to TriCaster
<b>Output Modes</b>	A;B; A+B
<b>Video Formats</b>	3Play 425-MS (Multi-standard): PAL 1080/25p, 1080/50i, 720/50p, 720/25p, 576/25i, NTSC, NTSC-J: 1080/30p, 1080/24p, 1080/60i, 720/60p, 720/30p, 720/24p, 480/60i 3Play 425 (North America): NTSC 1080/30p, 1080/24p, 1080/60i, 720/60p, 720/30p, 720/24p, 480/60i
<b>Recording Channels</b>	4
<b>Recording Capacity</b>	More than 30 hours of combined 1080i storage across internal drive and removable drive (15+ hours per drive) MPEG-2 all I-frame
<b>Genlock</b>	Locks to HD or SD analog signals Supports either tri-level or bi-level sync sources
<b>Multi-Viewer</b>	Supported with 2nd display, including HUD
<b>Audio Inputs</b>	4 SDI Embedded 3 x 2 Balanced 1/4" (Mic/Line) 1 x 2 Balanced XLR (Mic/Line)

<b>Audio Outputs</b>	2 SDI Embedded 1 x 2 Balanced XLR 1 x 2 Balanced 1/4"
<b>Audio Processing</b>	Audio is uncompressed and sampled at 96kHz, 32-bit
<b>Time Code</b>	LTC
<b>A/V Standards</b>	HD-SDI video conforms to SMPTE 292M SD video conforms to SMPTE 259M and ITU-R BT.656 Analog audio levels conform to SMPTE RP-155
<b>Controller</b>	Dedicated controller with T-bar, jog wheel, speed presets and clip transport
<b>Dimensions</b>	19 x 3.5 x 22.5 (in) 48.3 x 8.9 x 57.2 (cm)
<b>Weight</b>	28 lbs (12.7 kg)

Subject to change without notice.

FRONT

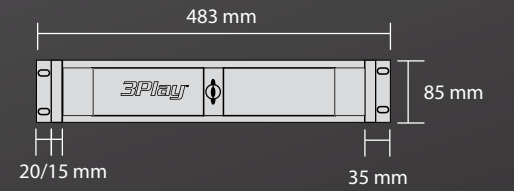

ABOVE

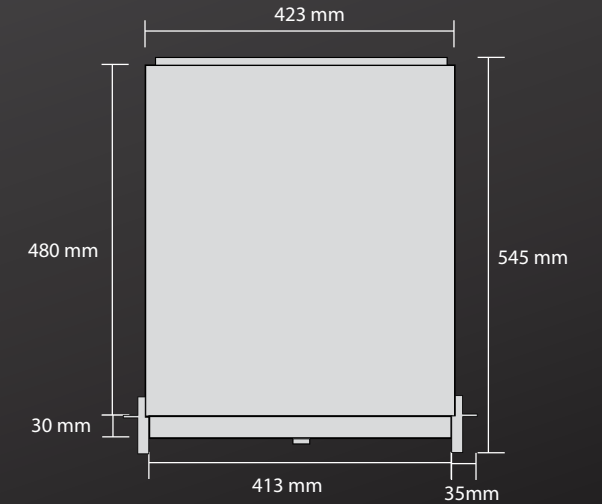

SIDE

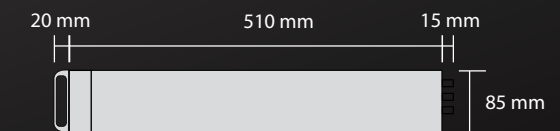

# Systems Comparative Tables

Features	TriCaster 40	TriCaster 410	TriCaster 460	TriCaster 860	TriCaster 8000
<b>Video Format</b>	HD/SD	HD/SD	HD/SD	HD/SD	HD/SD
<b>Digital I/O (SDI)</b>	—	✓	✓	✓	✓
<b>Analog I/O (Component, Composite, Y/C)</b>	✓	—	✓	✓	✓
<b>Pan-Tilt-Zoom (PTZ) Camera Support</b>	—	✓	✓	✓	✓
<b>External Video Router Support</b>	—	—	—	—	✓
<b>Switcher Channels</b>	14	15	15	24	24
<b>External Switcher Video Sources</b>	6	6	6	10	10
<b>Internal Switcher Video Sources</b>	3 + Black	4 + Black	4 + Black	5 + Black	5 + Black
<b>Re-Entrant M/E Buses</b>	—	—	—	—	8
<b>Standard M/E Buses</b>	—	4	4	8	—
<b>M/E-Style Virtual Inputs</b>	4	—	—	—	—
<b>Output Connections (max)</b>	5	5	9	12	14
<b>Recording Channels (max)</b>	1	1	4	8	8
<b>Recording Capacity (Hours)</b>	20 in HD	20 in HD	40 in HD	200 in HD	200 in HD
<b>Animation Buffers</b>	—	—	5	5	10
<b>Still &amp; Title Buffers</b>	—	15	10	10	5
<b>Live Virtual Sets</b>	24	30+	30+	30+	30+
<b>Live Streaming</b>	✓	✓	✓	✓	✓
<b>Media Publishing</b>	—	✓	✓	✓	✓
<b>IsoCorder™ Recording Technology</b>	—	—	✓	✓	✓
<b>TransWarp Effects</b>	✓	✓	✓	✓	✓
<b>Animation Store Transitions</b>	✓	✓	✓	✓	✓
<b>Holographic Live Virtual Set Support</b>	—	✓	✓	✓	✓
<b>Macros</b>	—	✓	✓	✓	✓
<b>Hot Spots</b>	—	✓	✓	✓	✓
<b>Real-Time Motion Tracking</b>	—	—	—	—	✓
<b>MIDI Support</b>	—	✓	✓	✓	✓
<b>Avid® Artist Mix Audio Control Support</b>	—	✓	✓	✓	✓
<b>Apple® AirPlay® Device Support</b>	✓	✓	✓	✓	✓
<b>Multi-View Monitoring</b>	✓	✓	✓	✓	✓
<b>Individually Configurable Multi-View Monitor Viewports</b>	—	—	—	—	✓
<b>Frame Sync Toggle (Ultra-Low Latency)</b>	—	—	—	✓	✓
<b>Genlock</b>	—	—	✓	✓	✓
<b>Tally</b>	—	✓	✓	✓	✓
<b>Removable Storage</b>	—	—	✓	✓	✓
<b>Hardware Fail-Safe</b>	—	✓	✓	✓	✓
<b>Redundant PSU</b>	—	—	—	✓	✓
<b>Software Fail-Safe</b>	✓	✓	✓	✓	✓
<b>System Mirroring</b>	—	—	—	—	✓
<b>Form Factor</b>	Desktop	2U Rack Mount	2U Rack Mount	4U Rack Mount	4U Rack Mount

Features	3Play 4800	3Play 425
<b>Video Format</b>	HD/SD	HD/SD
<b>Video Inputs</b>	8	4
<b>Playout Channels</b>	2 simultaneous, switchable, fully independent	2 simultaneous, switchable, fully independent
<b>Recording Channels</b>	Standard (8 channel) Redundant (4 channel)	4 channel
<b>Base Recording Capacity (hr)</b>	200 in HD	30 in HD
<b>Recording Format</b>	High-quality QuickTime	MPEG-2 all I-frame
<b>Multi-Speed Live Playback</b>	-200% to 200%	0% to 100%
<b>Template Sessions</b>	✓	—
<b>Media Publishing</b>	✓	—
<b>Transition Between Playout Channels</b>	✓	—
<b>Animation Store Transitions</b>	✓	—
<b>TransWarp Effects</b>	✓	—
<b>Animation Store Creator</b>	Included	—
<b>FastClip Asset Management</b>	✓	—
<b>Keyword Tagging Engine</b>	✓	—
<b>Bookmarks</b>	✓	—
<b>Grab Stills</b>	All Inputs and Outputs	—
<b>Playlist Transitions</b>	Standard, Animation Store Transitions	Crossfade
<b>Playlist Music Track</b>	✓	✓
<b>Clip Monitors</b>	✓	—
<b>Multi-View Monitoring</b>	✓	✓
<b>HDMI Output</b>	✓	✓
<b>AUX Output</b>	✓	—
<b>Network Output to TriCaster</b>	✓	✓
<b>Batch Media Import/Export</b>	✓	✓
<b>Import Media While Live</b>	✓	✓
<b>Genlock</b>	✓	✓
<b>Hardware Fail-Safe</b>	✓	✓
<b>Redundant PSU</b>	✓	✓
<b>Software Fail-Safe</b>	—	✓
<b>Removable Storage</b>	Four 2TB Media Drives	1TB Media Drive
<b>Form Factor</b>	4U Rack Mount	2U Rack Mount

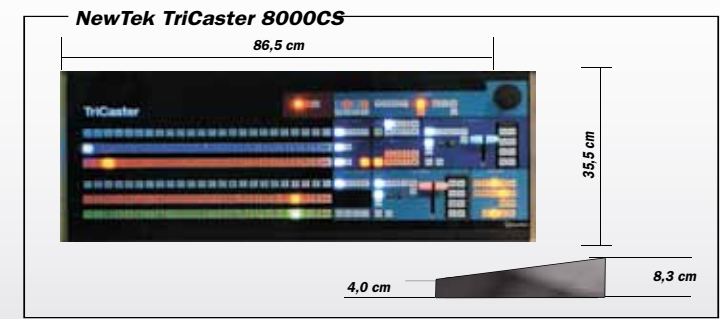
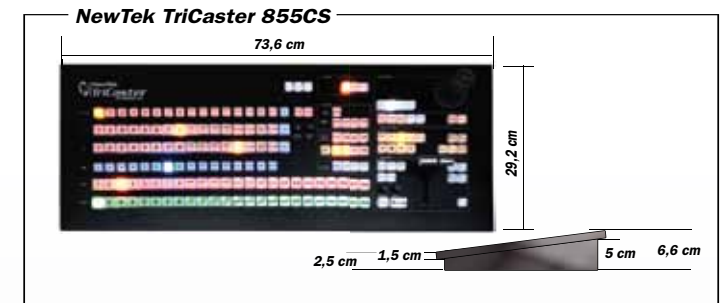
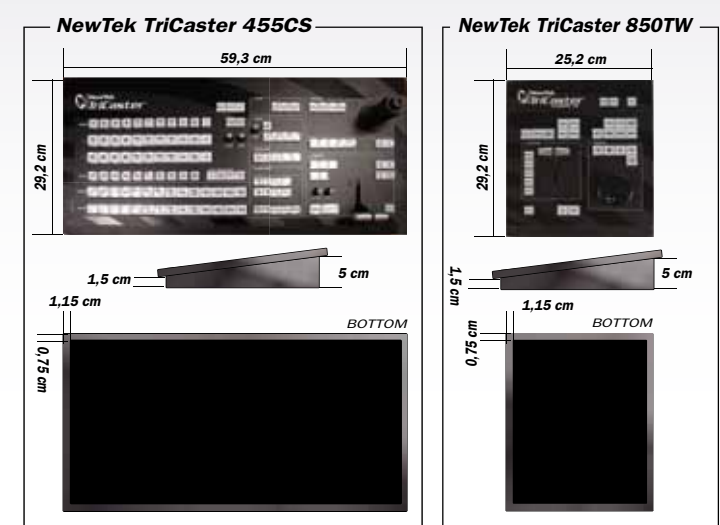



# Virtual Sets Templates

Virtual sets	Arena Report	City Hall	Downtown Church	Keynote	Power Play	Space News Holoset	Sports Net	Starship Bridge A	Starship Bridge B	Metropolis A	Metropolis B	3D	Alignment
TriCaster 8000	✓	✓	✓	✓	✓	✓	✓	✓	✓	✓	✓	✓	✓
TriCaster 860	✓	✓	✓	✓	✓	✓	✓	✓	✓	✓	✓	✓	✓
TriCaster 460	✓	✓	✓	✓	✓	✓	✓	✓	✓	✓	✓	✓	✓
TriCaster 410	—	—	—	—	—	—	—	—	—	—	—	✓	✓

Virtual sets	Alpha	City Loft	Corner Talk	Default	Demo Studio	Helix	Midday Report	News Line	Night Beat	Nightly show A	Nightly show B	Open Book	Optima
TriCaster 8000	✓	✓	✓	✓	✓	✓	✓	✓	✓	✓	✓	✓	✓
TriCaster 860	✓	✓	✓	✓	✓	✓	✓	✓	✓	✓	✓	✓	✓
TriCaster 460	✓	✓	✓	✓	✓	✓	✓	✓	✓	✓	✓	✓	✓
TriCaster 410	✓	✓	✓	✓	✓	✓	✓	✓	✓	✓	✓	✓	✓

Virtual sets	Plaza	Prime Time	Randomize	Rock Stage	SciTech	SkyBox	Space News	Split Screen	Stadium	World Update
TriCaster 8000	✓	✓	✓	✓	✓	✓	✓	✓	✓	✓
TriCaster 860	✓	✓	✓	✓	✓	✓	✓	✓	✓	✓
TriCaster 460	✓	✓	✓	✓	✓	✓	✓	✓	✓	✓
TriCaster 410	✓	✓	✓	✓	✓	✓	✓	✓	✓	✓



# Services



**3D Storm**, distributor of NewTek products in Europe, Middle-East, Africa, Turkey, Russia and Pakistan since 1999, is a leading player in the convergence of IT & the Broadcast industries.

**3D Storm** professional team delivers bespoke solutions through a network of Specialist and Authorized Dealers providing customers with an exclusive access to the newest and most innovative solutions on the market, such as TriCaster and 3Play.

**3D Storm** offers cost-effective solutions for anyone to bring their vision into real live television production.

**3D Storm** clients such as **BBC, Sky, Mediaset, RAI, Radio RAI, CNBC, Azzura TV, Telenova, TF1, France Televisions, BFM TV, RTL, WDR, MDR, RTBF, MBC Dubai, SBC Seychelles, TV4, Borsen TV, Kanal Sport Denmark, Super Sport South Africa, TVGA (TV de Galicia), TV3, Banco Santander, Real Madrid F.C, Arsenal Media, Paris Parc des Princes Stadium, Copenhagen Parken Stadium, City of Paris, European Parliament, Metropole Orchestra NL, Università di Modena e Reggio Emilia, Universidad Carlos III de Madrid, King Abdullah University Saudi Arabia...** deliver daily live and streaming productions with NewTek products.



#### Dealer Locator

3D Storm is working with an extended network of selected and skilled AV companies throughout Europe, Middle East, Africa and Russia. You can easily find the nearest NewTek Authorized and Specialist Dealer in your country using our on-line dealer locator.



#### Training Program

3D Storm offers high end bespoke training for TriCaster, 3Play and 3D Virtual Sets design for TriCaster. Our trainings can be combined with production and while learning the techniques you may apply them to one of your projects. Contact our sales department to organize your next training session.



#### CallBack

For any inquiry about our products do not hesitate to use 3D Storm FREE CALLBACK SERVICE accessible from 3dstorm.com Contact page. Enter your phone number and your preferred time to be contacted and we will call you back!



#### TriCaster Operator Certification

Become a Certified TriCaster™ Operator and add a valuable asset to your business. The NewTek TriCaster Certified Operator Exam is an opportunity to test your skills at creating a live production with TriCaster. Your Certification gives producers and directors confidence that your skills meet the demands of today's fast-paced production environment. Contact 3D Storm for any enquiry regarding TriCaster Operator Certification.

# Warranty and Extended Services



#### NewTek manufacturer warranty

The original warranty period for NewTek TriCaster and 3Play new equipment is twelve (12) months from the date of product purchase. This warranty includes parts and labour.

Find NewTek manufacturer warranty information on:  
<http://www.3dstorm.com/en/warranty>

#### **Extend Your Warranty and Protect Your Investment with 3D Storm!**

#### 3D Storm Exclusive "Services Plus"

- ✓ Free additional 6-month warranty extension on top of the 12-month NewTek manufacturer warranty.
- ✓ Priority Technical support by phone or email and a free call back service
- ✓ Free Pick-up & Return of defective equipment during warranty period
- ✓ Free Loaner if repair shall take more than 10 business days

For product eligibility and more information about 3D Storm Free Exclusive Services Plus, visit [www.3dstorm.com](http://www.3dstorm.com)

#### Extended Services – Services Plus Gold Star Program

On top of the 12-month NewTek manufacturer warranty, 3D Storm offers NEW services, the **Services Plus Gold Star Program**. This 3D Storm

Warranty Extension Program safeguards your NewTek equipment investment for an additional year, or two, providing the reliability and convenience benefits of your original warranty.

#### Key Benefits

- ✓ Extend the original warranty for an additional 12- or 24-months.
- ✓ Free Callback service.
- ✓ "Express pick-up and loan within 24h" available option.
- ✓ Priority repair service.
- ✓ Priority Tech support during the warranty time
- ✓ The Warranty Extension is transferable and adds to the resale value.

This program is available through 3D Storm "Specialist" and "Authorized" NewTek resellers in Europe (EEC) (including Switzerland, except United Kingdom and Nordic countries ).

With Services Plus and Services Plus Gold Star program, your warranty is extended from 18 months to 30 months on top of manufacturer warranty.

Contact 3D Storm to know more about Services Plus and Services Plus Gold Star Program.

<http://www.3dstorm.com/en/warranty>





SOLUTIONS FOR TELEVISION PRODUCTION & VIDEO STREAMING



[www.3dstorm.com](http://www.3dstorm.com)

*The Distributor of NewTek products for Europe, Middle East, Africa, Turkey, Russia and Pakistan*  
70, Avenue de Capeyron - 33160 Saint-Medard-en-Jalles, France - T: + 33 (0) 5 57 262 262 - F:+ 33 (0) 5 57 262 261 - [info@3dstorm.com](mailto:info@3dstorm.com)

NewTek and TriCaster are trademarks of NewTek.  
All other products or brand names mentioned are trademarks or registered trademarks of their respective holders.  
All Rights Reserved - ©3D Storm 2013